

HEAD PROFILE

JAMB PROFILE

NOTE: FRAME BY TOTAL DOOR

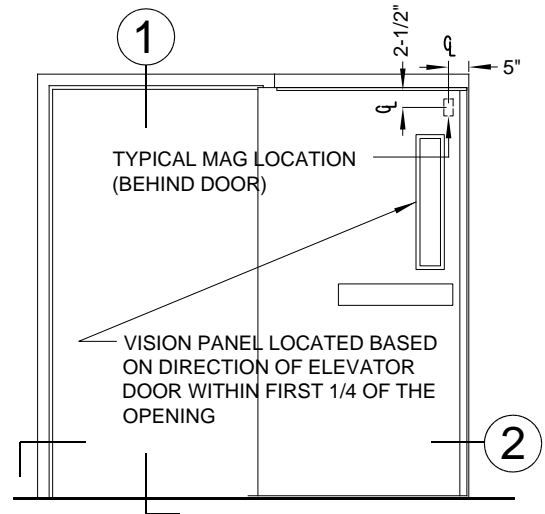

1 VERTICAL SECTION

NOT TO SCALE

ELEVATION

NOT TO SCALE

JUNCTION BOX ONLY REQUIRED FOR TDH200 MAG
 LOCATED 5" FROM END OF POCKET AND 2-1/2"
 DOWN FROM TOP OF DOOR

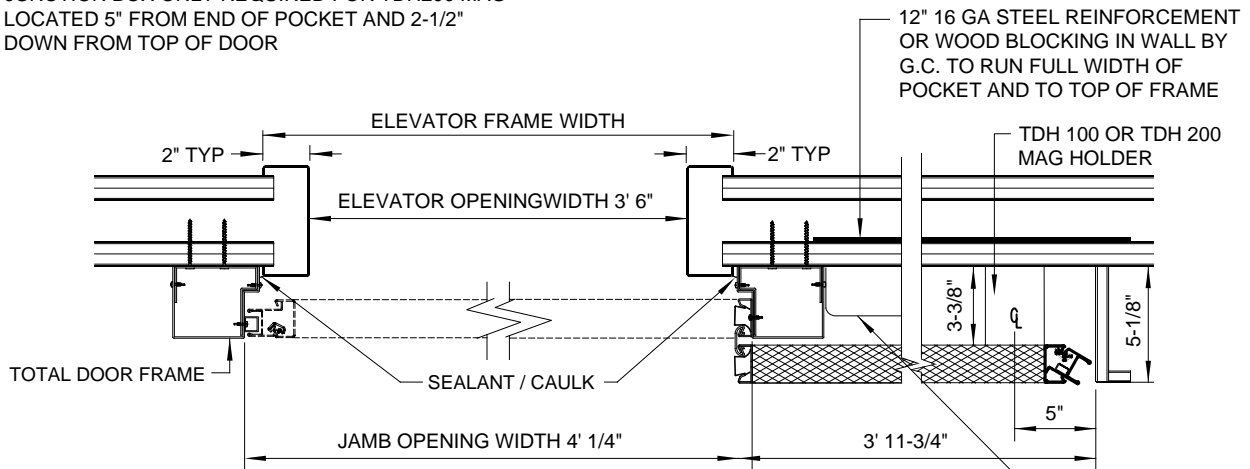

JAMB WIDTH = ELEVATOR OPENING WIDTH + 1-1/4" + (FACE OF FRAME X 2) + 1"
 JAMB HEIGHT = ELEVATOR OPENING HEIGHT + 5/8" + (FACE OF FRAME X 1) + 1/2"

2 HORIZONTAL SECTION

NOT TO SCALE

MIN. 1" CLEARANCE REQUIRED FROM CEILING AND TO TOP OF POCKET TO FRAME RABBET

HOLLOW METAL FRAME FOR TOTAL DOOR

SEALANT CONTINUOUS ALONG JOINT BETWEEN DOOR FRAME AND ELEVATOR FRAME

FIELD APPLIED SMOKE SEAL

TOTAL DOOR CONTINUOUS HINGE

TOTAL DOOR SHOWN IN 180° OPEN POSITION

ELEVATOR FRAME

STD. UNDERCUT 3/4"

SURFACE MOUNTED SMOKE SEAL

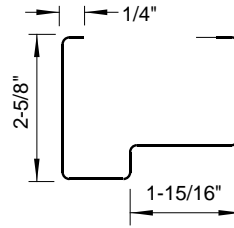

HEAD PROFILE

NOTE: FRAME BY OTHERS

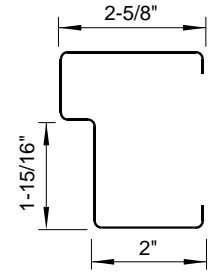

JAMB PROFILE

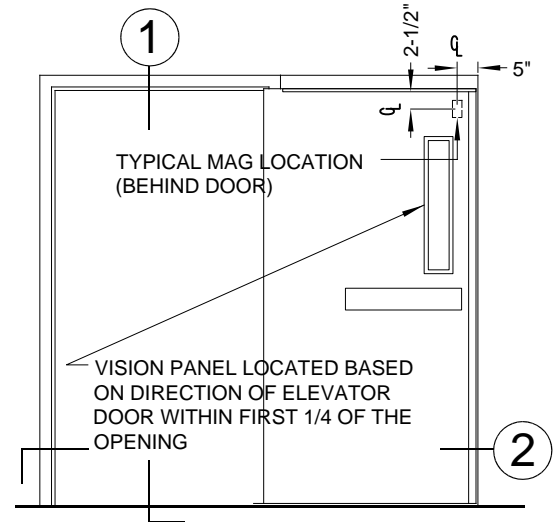

ELEVATION

NOT TO SCALE

1

VERTICAL SECTION

NOT TO SCALE

JUNCTION BOX ONLY REQUIRED FOR TDH200 MAG LOCATED 5" FROM END OF POCKET AND 2-1/2" DOWN FROM TOP OF DOOR

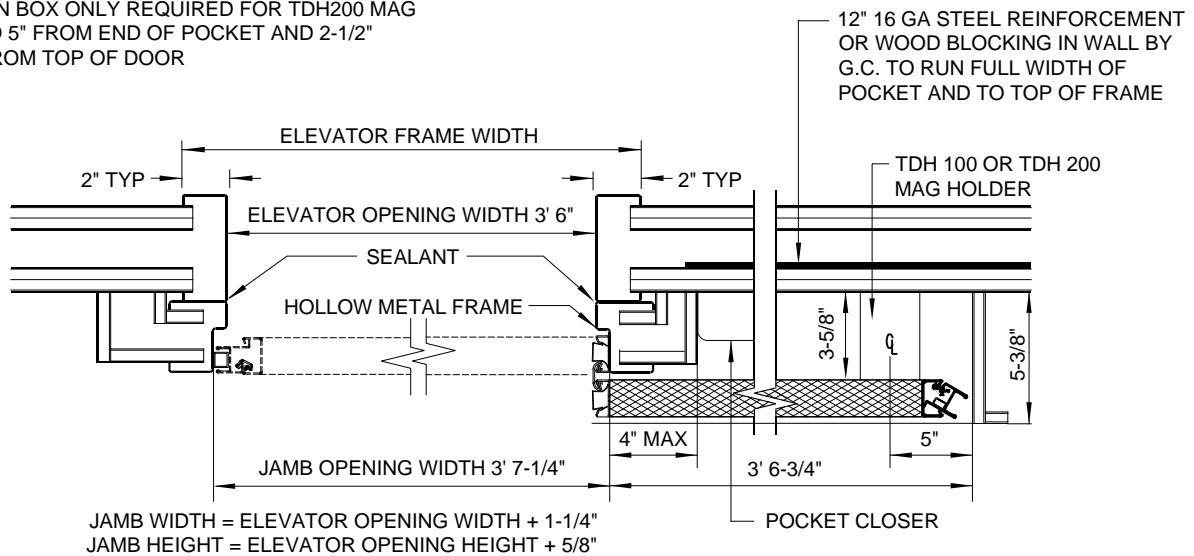

2

HORIZONTAL SECTION

NOT TO SCALE

MIN. 1" CLEARANCE REQUIRED FROM CEILING AND TO TOP OF POCKET TO FRAME RABBET

HOLLOW METAL FRAME FOR TOTAL DOOR

SEALANT CONTINUOUS ALONG JOINT BETWEEN DOOR FRAME AND ELEVATOR FRAME

FIELD APPLIED SMOKE SEAL

TOTAL DOOR CONTINUOUS HINGE

TOTAL DOOR SHOWN IN 180° OPEN POSITION

ELEVATOR FRAME

STD. UNDERCUT 3/4"

SURFACE MOUNTED SMOKE SEAL

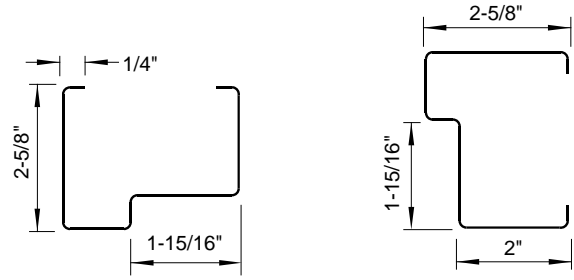
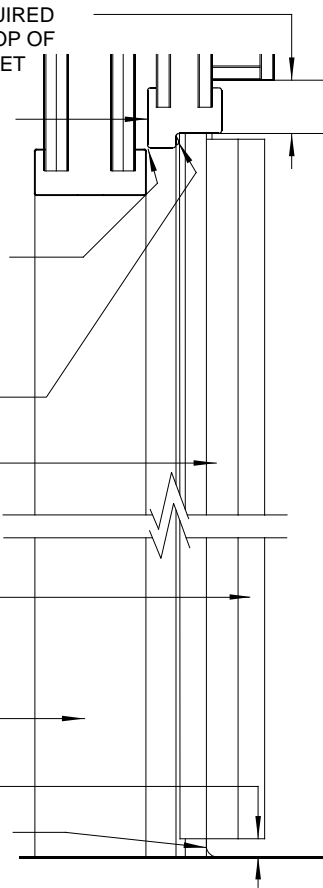

HEAD PROFILE

JAMB PROFILE

NOTE: FRAME BY OTHERS

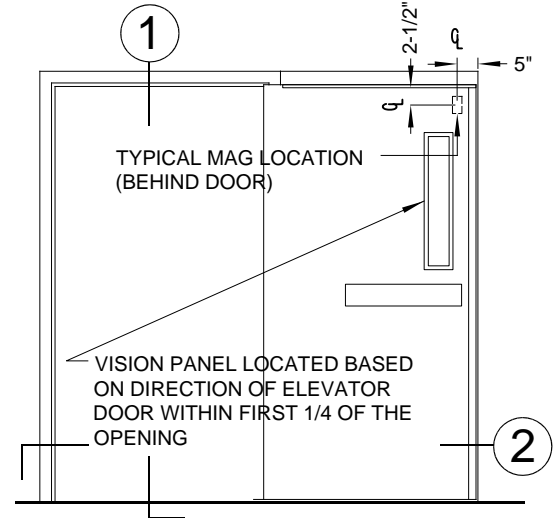

1 VERTICAL SECTION

NOT TO SCALE

ELEVATION

NOT TO SCALE

JUNCTION BOX ONLY REQUIRED FOR TDH200 MAG LOCATED 5" FROM END OF POCKET AND 2-1/2" DOWN FROM TOP OF DOOR

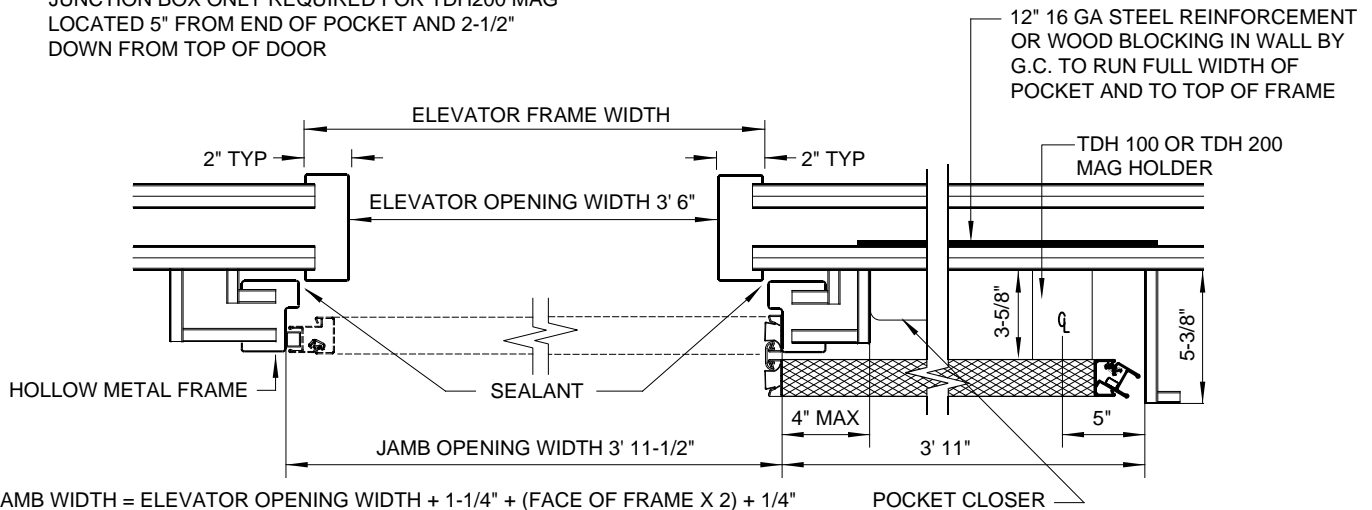

JAMB WIDTH = ELEVATOR OPENING WIDTH + 1-1/4" + (FACE OF FRAME X 2) + 1/4"
 JAMB HEIGHT = ELEVATOR OPENING HEIGHT + 1/8" + (FACE OF FRAME X 1) + 5/8"

2 HORIZONTAL SECTION

NOT TO SCALE