

INSTALLATION PROCEDURES FOR THE TDC 96

- 1). Install the Total Door according to the installation instructions.
- 2). Insert the Y-103 slider into the track. When specified, install the cushioned stop as shown.
- 3). Use the 5/32" portion of the installation key to install the track at the proper distance from the door. Install one screw at each end of the track loosely then attach the arm to the slider.
- 4). Tighten the end screws and install the remaining screws.
- 5). Adjust closer if needed.
- 6). Set cushioned stop as desired to enable swing between 80 and 130 degrees.

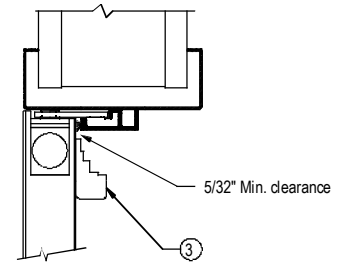

The bumper stop cushions the opening swing of the door. It is not intended to act as a door stop. Failure to install an auxiliary stop may cause damage to the door.

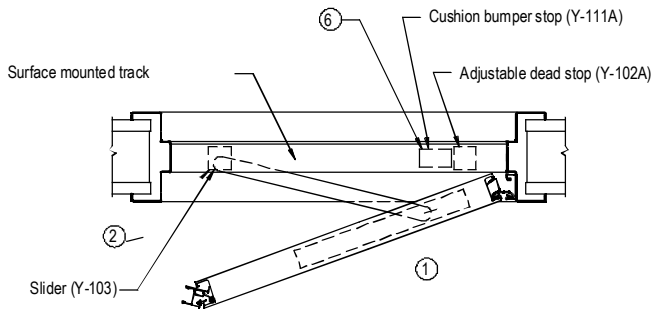
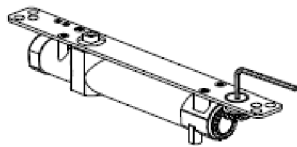

5MM HEX WRENCH

CRITICAL

NOTE: Closer is normally supplied with minimum spring setting as a size 1. Clockwise turns increase spring tension.

NOTE: MAXIMUM NUMBER OF TURNS - 17

BARRIER - FREE OPENINGS - Adjust only if more tension is required to close and latch the door. Depending on opening conditions, a door adjusted to meet barrier - free forces may not have sufficient power to reliably close and latch the door.

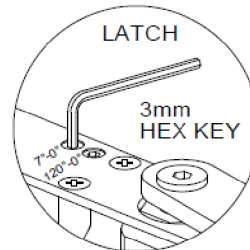
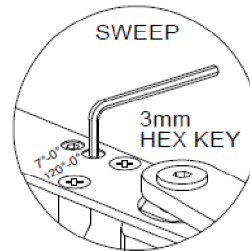

Adjust sweep and latch valves.

CAUTION: DO NOT REMOVE VALVES

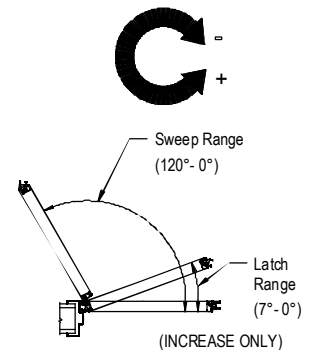

⑤ Adjust spring tension.