

HEAD PROFILE JAMB PROFILE

NOTE: SAFEFRAME BY TOTAL DOOR

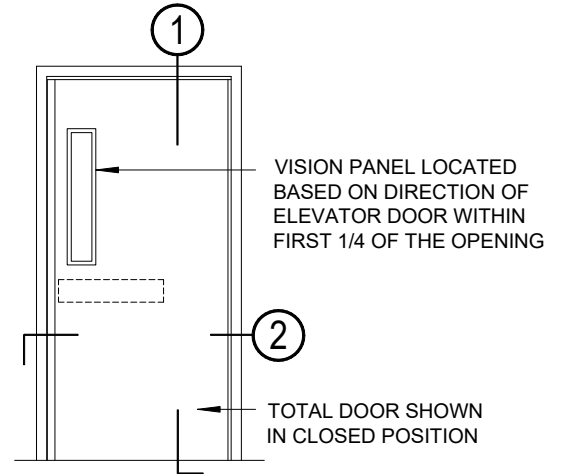

ELEVATION

NOT TO SCALE

1 VERTICAL SECTION

NOT TO SCALE

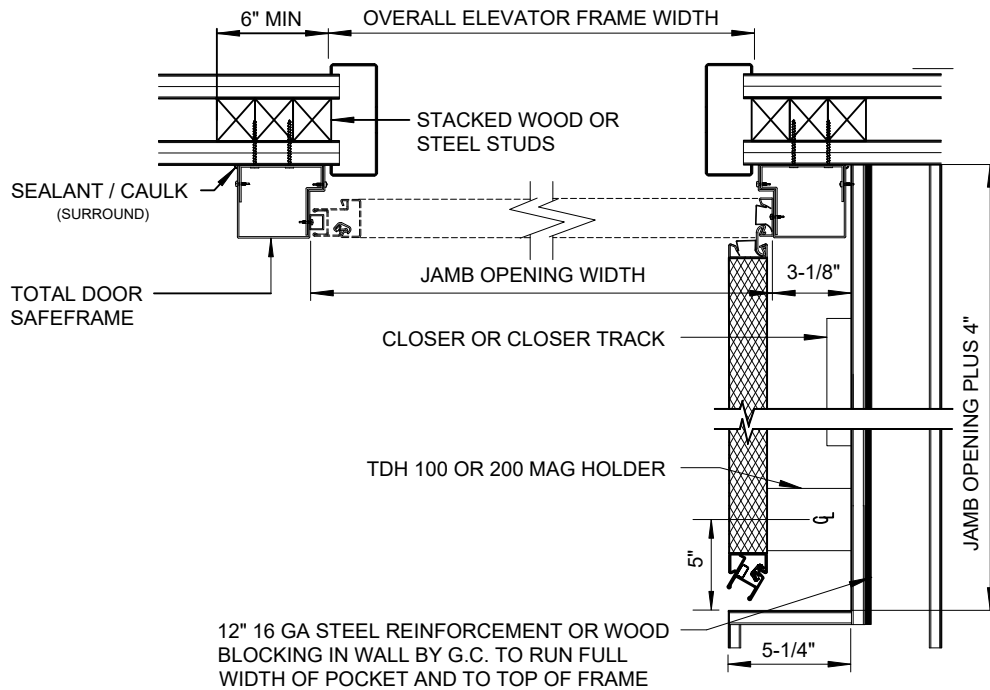

2 HORIZONTAL SECTION

NOT TO SCALE

JAMB WIDTH = OVERALL ELEVATOR FRAME WIDTH + 2"
 JAMB HEIGHT = OVERALL ELEVATOR FRAME HEIGHT + 1"