

Certificate of Compliance



Intertek

This is a certificate of compliance to certify that the bearer has successfully completed the requirements of the above scheme which include the testing of products, the initial assessment, and are subject to continuing annual assessments of their compliance and testing of samples of products taken from production (as applicable to the scheme) and has been registered within the scheme for the products detailed.

You have been awarded:

Intertek Warnock Hersey Mark for Steel Fire Doorset - Polystyrene or Mineral core

UL 10C (1998); UBC 7-2 (1997); CAN4 S104 (1985); UL 10C (2009); UL 1784 (2009); CAN/ULC S104 (2010); NFPA 252 (2012); UL 10C (2016); CAN/ULC S104 (2015); UL 1784 (2015); NFPA 252 (2017)

Certificate number: WHI17 – 29795402

Organization:

Total Door II, Inc.

6145 Delfield
Industrial Drive
Waterford, MI 48329

Product: Steel Fire Doorset – Polystyrene or Mineral core Rating: Up to 180 minutes for Fire Endurance & Hose stream Test Temperature Rise: Greater than 650 degrees F at 30 minutes for Polystyrene core, less than 250 degrees F at 30 minutes for Mineral core

TOTAL DOORS have been tested as per, Category D, which includes doors and frames that are labeled for positive pressure compliance as a complete assembly. A Category D assembly includes all of the following: doors, frames, and all hardware as noted within the product listing.

Construction:

Frame: All frame constructions shown in UL-63 are usable with Total Door. Total Doors may be used with all labeled frames of any manufacturer per the frame manufacturer's listings. Total Doors may be retrofitted to any existing labeled frames that are structurally sound.

Doors: Door bodies are 20 or 18 Gauge steel skins with continuous 16 gauge steel hinge and latch reinforcements. 5 1/2" 18 gauge top and bottom rails. Cores are of polystyrene or mineral core.

3 hour - Steel doors, polystyrene core, with temperature rise over 650 degrees F. with:

- a) 20 & 18 Gauge skins.
- b) Single swing with maximum size of 4' 0" x 8' 0".
- c) Pairs and double egress with maximum size of 8' 0" x 8' 0".
- d) Levers, operating push/pull grips and panic devices, all without the use of Coordinators, flush bolts, astragals, vertical rods or floor strikes
- e) Certified to UL 10C (2016), NFPA 252 (2017), CAN/ULC S104 (2015), UL 1784 (2015). Uses WH C US Mark.

3 hour - Steel doors, mineral core, with temperature rise less than 250 degrees F. with:

- a) 18 Gauge skins.
- b) Single swing with maximum size of 4' 0" x 8' 0".
- c) Pairs and double egress with maximum size of 8' 0" x 8' 0".
- d) Levers, operating push/pull grips and panic devices, all without the use of Coordinators, flush bolts, astragals, vertical rods or floor strikes.
- e) Certified to UL 10C (2016), NFPA 252 (2017), CAN/ULC S104 (2015), UL 1784 (2015). Uses WH C US Mark.

www.intertek.com

Certificate of Compliance



This is a certificate of compliance to certify that the bearer has successfully completed the requirements of the above scheme which include the testing of products, the initial assessment, and are subject to continuing annual assessments of their compliance and testing of samples of products taken from production (as applicable to the scheme) and has been registered within the scheme for the products detailed.

1½ & ¾ hour - Steel doors, polystyrene core, with temperature rise over 650 degrees F. with;
a) 20 Gauge skins maximum size single swing- 4' 2-3/16" x 9' 0"
b) 20 Gauge skins maximum size pair & double egress swing- 8' 4-3/8" x 9' 0"
c) 18 Gauge skins maximum size single swing- 4' 0" x 9' 0"
d) 18 Gauge skins maximum size pair & double egress swing- 8' 0" x 9' 0"
e) Levers, operating push/pull grips and panic devices, all without the use of Coordinators, flush bolts, astragals, vertical rods or floor strikes.
f) Certified to UL 10C (2016), NFPA 252 (2017), CAN/ULC S104 (2015), UL 1784 (2015). Uses WH C US Mark.

1½ hour - Steel doors, mineral core, with temperature rise less than 250 degrees F. with;
a) 20 Gauge skins size single swing- >4' to the max. of 4' 2-3/16" x 9' 0"
b) 20 Gauge skins size pair & double egress swing- >8' to the max of 8' 4-3/8" x 9' 0"
c) 18 Gauge skins maximum size single swing- 4' 0" x 9' 0"
d) 18 Gauge skins maximum size pair & double egress swing- 8' 0" x 9' 0"
e) Levers, operating push/pull grips and panic devices, all without the use of Coordinators, flush bolts, astragals, vertical rods or floor strikes.
f) Certified to UL 10C (2016), NFPA 252 (2017), CAN/ULC S104 (2015), UL 1784 (2015). Uses WH C US Mark.

20 minute (with hose stream) - Steel doors, polystyrene core with;
a) 20 Gauge skins maximum size single swing- 4' 2-3/16" x 9' 0"
b) 20 Gauge skins maximum size pair & double egress swing- 8' 4-3/8" x 9' 0"
c) 18 Gauge skins maximum size single swing- 4' 0" x 9' 0"
d) 18 Gauge skins maximum size pair & double egress swing- 8' 0" x 9' 0"
e) Levers, operating push/pull grips and panic devices, all without the use of Coordinators, flush bolts, astragals, vertical rods or floor strikes.
f) Certified to UL 10C (2016), NFPA 252 (2017), CAN/ULC S104 (2015), UL 1784 (2015). Uses WH C US Mark.

20 minute (without hose stream) - Steel doors, polystyrene core with;
a) 20 Gauge skins maximum size single swing- 4' 2-3/16" x 10' 0"
b) 20 Gauge skins maximum size pair & double egress swing- 8' 4-3/8" x 10' 0"
c) 18 Gauge skins maximum size single swing- 4' 2-3/16" x 10' 0"
d) 18 Gauge skins maximum size pair & double egress swing- 8' 4-3/8" x 10' 0"
e) Levers, operating push/pull grips and panic devices, all without the use of Coordinators, flush bolts, astragals, vertical rods or floor strikes.
f) See Spec ID 27453 for further information. Certified to UL 10C (2016) and NFPA 252 (2012). Uses WH US Mark.

Door Hardware:

- Closers - Mortised closers are approved for all fire ratings including three (3) hour.
Electric - Electric doors, with inclusion of a solenoid for remote control of locking/latching is approved on all labels as part of the door system. A separate label for the solenoid is not required when installed in the lower 40" of the door.
Holders - Mortised semi-concealed electromagnetic holder mounted in the door for all labels.

Certificate of Compliance



This is a certificate of compliance to certify that the bearer has successfully completed the requirements of the above scheme which include the testing of products, the initial assessment, and are subject to continuing annual assessments of their compliance and testing of samples of products taken from production (as applicable to the scheme) and has been registered within the scheme for the products detailed.

Lights – Glazing & Door light frames/kits shall be listed and labeled for use in the rated opening.

A steel channel of 16 or 18 gauge shall be installed between the two faces and shall be mechanically fastened in the corners. A strip of listed glazing tape that is listed for use with the specific listed glass shall be placed on both surfaces of glass between the glass and the light kit.

Groove for glazing depth*:

Visible glazing area (sq. inch)	Minimum groove depth (inch)
0 - 300	1/2
301 - 400	9/16
401 - 500	5/8
501 - 600	11/16
601 - 1296	3/4

Cutouts shall not be less than 5-1/2 inches from door edges or other door cutouts. Cutout shall not cut reinforcements or stiffeners.

Visible glazing*:

Rating (hour)	1/3, 3/4	1, 1-1/2, or Lead-Lined Doors
Maximum area:	1,296 sq. in.	100 sq. in.
Maximum height:	54	33
Maximum width:	30	10

Multiple panels are permitted in 1/3 and 3/4-hour doors when the sum of the areas does not exceed 1,296 square inches with above maximum height and width limitations for each panel.

*When using FireLite Plus or FireLite NT glazing, the max. size and min. depth of groove limitations shown in the table below are applicable:

Rating	Max. Visible Glass (in. ²)	Max. Visible Glass Widths (in.)	Max. Visible Glass Lengths (in.)	Min. depth of groove (in.)
3 hr	100	12	33	1/2
1-1/2 hr	2034	36	56	3/4 for non-temp. rise 1/2 for temp. rise
3/4 hr	3204	36	89	5/8
20 Minute	3204	36	89	5/8

Note 1: Temperature Rise labels: 100 in.2 maximum for all ratings, 10 max. visible width, 33 in. max. visible height.

Note 2: Multiple panels are permitted when the sum of the areas does not exceed the max. visible glass area with the above max. width and height limitations for each panel. The minimum distance between lites shall remain at 5-1/2 in. The 5-1/2 in. minimum spacing also applies to lite to door edge and lite to other hardware cut-out clearances.

Note 3: The glazing compound may be pure silicone caulk, closed cell PVC or DAP 33. Other listed fire glazing tapes can also be used. For 1-1/2 hour applications, ceramic glazing tape must be used.

Certificate of Compliance



This is a certificate of compliance to certify that the bearer has successfully completed the requirements of the above scheme which include the testing of products, the initial assessment, and are subject to continuing annual assessments of their compliance and testing of samples of products taken from production (as applicable to the scheme) and has been registered within the scheme for the products detailed.

Kick plates – Labeling shall not be required where the top of the protection plate is not more than 16 in. (406 mm) above the bottom of the door. Any height, when using Total Door standard bonded wrap around protection plates of Maximum 0.028 inch thick brass, bronze, steel, stainless steel, and aluminum without mechanical fasteners. Plates are to be attached to faces with contact adhesives.

Exit Devices – The exit device is an integral part of the door assembly and may be used with: Push/Pull Operating Grips, Lever Mechanisms, or Panic (Push Plate) Exit Devices. These devices meet the criteria found in UL 305 and can be independently labeled. Exit Devices must be listed as fire exit hardware.

Smoke & Draft - The Total Door and frame assembly were tested in conjunction to test method UL 1784, "Standard for Air Leakage Tests of Door Assemblies." The assembly must have a fire rated air foil W-12 seal applied to the stop of the frame head (field applied) and to the inside of the door's locking channel (factory applied) to meet the air leakage compliance noted below. When required to be tested in accordance with UL 1784 "without an artificial bottom seal", an additional W60 fire rated smoke seal (surface or concealed) is required at the bottom of the door. Refer to Spec ID 25495 for further information.

Standard / Code Section	Description	Results
2009 IBC Section 711.5.2 and 2012 IBC Section 710.5.2.2 (Air Leakage Requirement)	Max. air leakage: < 3 cfc per sq.ft. of opening at 0.1 in. of w.c. pressure differential at ambient temperature.	Complies
2009 IBC Section 711.5.2 and 2012 IBC Section 710.5.2.2 (Air Leakage Requirement)	Max. air leakage: < 3 cfc per sq.ft. of opening at 0.1 in. of w.c. pressure differential at 400 degrees F.	Complies

Special Finishes - All labeled steel doors including temperature rise may have Architectural film, genuine wood veneers (non-combustible material UL/ULC/WH approved claddings), stainless steel (except Type 302), aluminum or brass faces ((1250 x 2450) with a maximum thickness of 1/8" (3.2mm)) on one or both sides but must be factory installed.

DOUBLE EGRESS

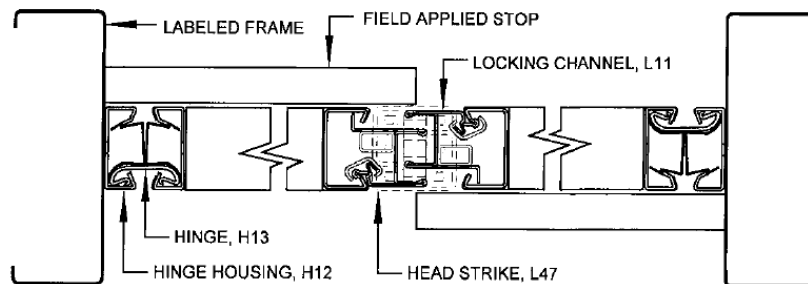

SAME SWING PAIR

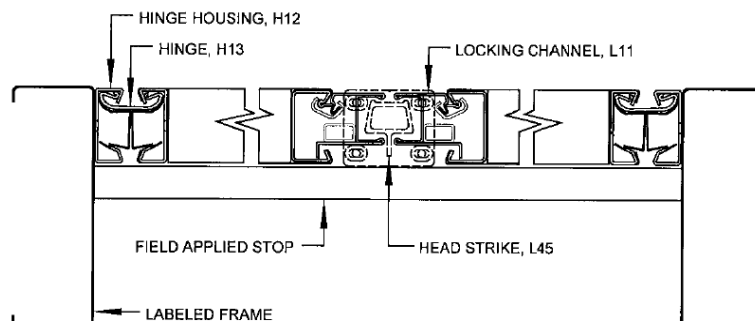

www.intertek.com

The certificate and schedule are held in force by regular annual surveillance visits by Intertek Testing Services NA, Inc. and the reader or user should contact Intertek to validate its status. This certificate remains the property of Intertek Testing Services NA, Inc. and must be returned to them on demand. This Certificate is for the exclusive use of Intertek's Client and is provided pursuant to the Certification agreement between Intertek and its Client. Intertek's responsibility and liability are limited to the terms and conditions of the agreement. Intertek assumes no liability to any party, other than to the Client in accordance with the agreement, for any loss, expense or damage occasioned by the use of this certificate. Only the Client is authorized to permit copying or distribution of this certificate and then only in its entirety. Use of Intertek's Certification mark is restricted to the conditions laid out in the agreement. Any further use of the Intertek name for the sale or advertisement of the tested material, product or service must first be approved in writing by Intertek. Initial Factory Assessments and Follow up Services are for the purpose of assuring appropriate usage of the Certification mark in accordance with the agreement, they are not for the purposes of production quality control and do not relieve the Client of their obligations in this respect.

Certificate of Compliance



This is a certificate of compliance to certify that the bearer has successfully completed the requirements of the above scheme which include the testing of products, the initial assessment, and are subject to continuing annual assessments of their compliance and testing of samples of products taken from production (as applicable to the scheme) and has been registered within the scheme for the products detailed.

SINGLE

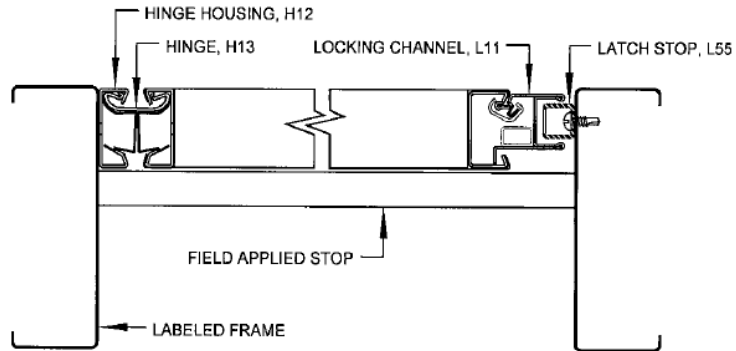

Specialty Elevator Door Frame (Spec ID 53823): For use in front of Elevator Doors. The assembly uses a proprietary surface mounted 16 gauge steel frame. Approved for use with Total Door only. Doors have a proprietary continuous hinge and interlocking latch system. The assembly must have a fire rated air foil W12 applied at the head of the frame and a W60 fire rated smoke seal (surface or concealed) at the bottom of the door (field applied), and a fire rated air foil W12 applied to the inside of the door's locking channel (factory applied). Standard pairs must have equal sized door leaves.

Size Limitation:
Maximum Nominal Width: 58-1/4"
Maximum Nominal Height: 101-1/8"

Dimensions		
Configuration	Width	Height
Clear Opening	58-1/4"	101-1/8"

Limitations*: The following proprietary components are provided with the system: Latches & Hinge System, Frame/Surface-Mounted Closers, Concealed Closer Arms, Surface-Mounted Protection Plates, Viewer, Surface Mounted or Mortised Door Bottoms. Metal Edge or Astragal is not required.

*Additional information is provided in the manufacturer's installation instructions for smoke and draft control size restrictions and limitations.

Ratings Achieved

The product noted above has been tested and qualified for fire resistance ratings per UL 10C, NFPA 252, and CAN / ULC S104 up to and including 90 minute applications. Temperature rise is greater than 650°F at 30 minutes on polystyrene core doors and less than 250°F at 30 minutes on mineral core doors.

The assembly has been tested in accordance with UL 1784. Results were achieved at four differential pressures ranging from 0.05 to 0.3 in. water column (12 to 75 Pa).

Standard/Code Section	Property	Results
UL 1784	Maximum air leakage at 0.05, 0.1, 0.2 and 0.3 inches of water column differential at ambient and elevated (400°F) temperature.	< 3.0 cfm/ft2

Note: This assembly was tested without an artificial bottom seal. The assembly may be installed in areas where pressurization is provided to control smoke movement in accordance with Section 4.3.2 of NFPA 105 (2019) and for hoistway opening protection and lobby doorways as allowed in Chapter 30 of the 2018 IBC.

Certificate of Compliance



This is a certificate of compliance to certify that the bearer has successfully completed the requirements of the above scheme which include the testing of products, the initial assessment, and are subject to continuing annual assessments of their compliance and testing of samples of products taken from production (as applicable to the scheme) and has been registered within the scheme for the products detailed.

TECHNICAL DATA SHEET # 60A					
DOOR CONSTRUCTION FOR POSITIVE PRESSURE B, C & 20 MIN. LABELS					
<p style="text-align: center;">ELEVATION</p>	<p>FIRE LABELS MAY BE 1-1/2 HR., 3/4 HR. OR 20 MIN. AND TEMPERATURE RISE AND SMOKE AND DRAFT</p> <p>FACES MAY BE 20 OR 18 GA. STEEL</p> <p>FINISHES MAY BE; PRIME, POLYURETHANE, WOOD VENEER, VINYL, ST. STEEL., BRASS OR BRONZE</p> <p>CORE MAY BE POLYSTYRENE (STD) MINERAL CORE, TEMP. RISE, 250'</p>				
<p>Total Door SYSTEMS™ Global Leader in Integrated Access Technology™</p>	<p>TEL. (800) 852-6660 www.totaldoor.com © Total Door 2021</p>	<table border="1" style="width: 100%; border-collapse: collapse;"> <tr><td style="padding: 2px;">FILE NAME</td></tr> <tr><td style="padding: 2px;">TDS60A</td></tr> <tr><td style="padding: 2px;">DATE 4/6/2021</td></tr> </table>	FILE NAME	TDS60A	DATE 4/6/2021
FILE NAME					
TDS60A					
DATE 4/6/2021					

Certificate of Compliance



This is a certificate of compliance to certify that the bearer has successfully completed the requirements of the above scheme which include the testing of products, the initial assessment, and are subject to continuing annual assessments of their compliance and testing of samples of products taken from production (as applicable to the scheme) and has been registered within the scheme for the products detailed.

TECHNICAL DATA SHEET # 60E				
DOOR CONSTRUCTION FOR POSITIVE PRESSURE A LABELS				
<p style="text-align: center;">ELEVATION</p>	<p>FIRE LABELS MAY BE 3 HR. AND TEMPERATURE RISE AND SMOKE AND DRAFT</p> <p>FACES MAY BE 20 OR 18 GA. STEEL</p> <p>FINISHES MAY BE; PRIME, POLYURETHANE, WOOD VENEER, VINYL, ST. STEEL, BRASS OR BRONZE</p> <p>CORE MAY BE POLYSTYRENE (STD) MINERAL CORE, TEMP. RISE, 250°</p>			
	TEL. (800) 852-6660 www.totaldoor.com © Total Door 2021			
<table border="1" style="width: 100%; border-collapse: collapse;"> <tr> <td style="padding: 2px;">FILE NAME</td> </tr> <tr> <td style="padding: 2px;">TDS60E</td> </tr> <tr> <td style="padding: 2px;">DATE 4/6/2021</td> </tr> </table>		FILE NAME	TDS60E	DATE 4/6/2021
FILE NAME				
TDS60E				
DATE 4/6/2021				

Certificate of Compliance



This is a certificate of compliance to certify that the bearer has successfully completed the requirements of the above scheme which include the testing of products, the initial assessment, and are subject to continuing annual assessments of their compliance and testing of samples of products taken from production (as applicable to the scheme) and has been registered within the scheme for the products detailed.

TECHNICAL DATA SHEET # 6d 00

SAFEFRAME™

4'10 ¹/₄\" MAX

85 ¹/₈\" MAX

3 ⁵/₈\"

16 GA STEEL

3\"

JAMB PROFILE

4'10 ¹/₄\" MAX

FRAME IS ANCHORED TO STEEL OR WOOD STUDS OR CONCRETE

Total Door
Global Leader in Integrated Access Technology™

TEL: (800) 852-6660
www.totaldoor.com
© Total Door 2020

FILE NAME
TDSD
DATE: 04/06/2021

Check Listing report ref 27453, 25495, 25496, 25499, 21633, 53823 & Test reports ref. 3079311, 3149284MID-006 & 3190974MID-002 for full details.

Certification body: Intertek Testing Services NA, Inc.
Initial registration: September 1st, 2017
Date of expiry: December 31st, 2025
Issue status: 7

<p style="text-align: center;">Jean-Philippe Kayl Vice President, Global Certification</p>		<p style="text-align: right;">January 1, 2025</p>
Name	Signature	Date

Registered address:
Intertek Testing Services NA, Inc. 545 E. Algonquin Rd. Arlington Heights, IL 60005 USA

www.intertek.com

The certificate and schedule are held in force by regular annual surveillance visits by Intertek Testing Services NA, Inc. and the reader or user should contact Intertek to validate its status. This certificate remains the property of Intertek Testing Services NA, Inc. and must be returned to them on demand. This Certificate is for the exclusive use of Intertek's Client and is provided pursuant to the Certification agreement between Intertek and its Client. Intertek's responsibility and liability are limited to the terms and conditions of the agreement. Intertek assumes no liability to any party, other than to the Client in accordance with the agreement, for any loss, expense or damage occasioned by the use of this certificate. Only the Client is authorized to permit copying or distribution of this certificate and then only in its entirety. Use of Intertek's Certification mark is restricted to the conditions laid out in the agreement. Any further use of the Intertek name for the sale or advertisement of the tested material, product or service must first be approved in writing by Intertek. Initial Factory Assessments and Follow up Services are for the purpose of assuring appropriate usage of the Certification mark in accordance with the agreement, they are not for the purposes of production quality control and do not relieve the Client of their obligations in this respect.