

# TECHNICAL DATA SHEET # 36

02

## TOTAL-DOOR INSTALLATION "KEY"

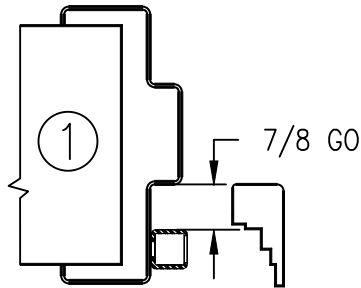

**LATCH STOP TO FRAME STOP**  
USE 7/8 PORTION OF "KEY" TO  
CHECK PROPER STOP POSITION

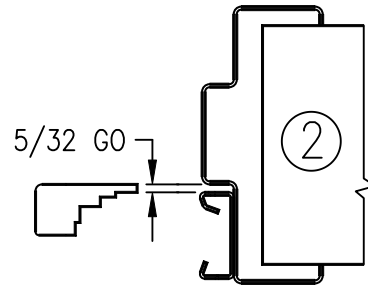

**HINGE HS'G TO FRAME STOP**  
USE 5/32 PORTION OF "KEY"  
TO CHECK FOR MINIMUM CLEARANCE  
AT TOP OF JAMB.

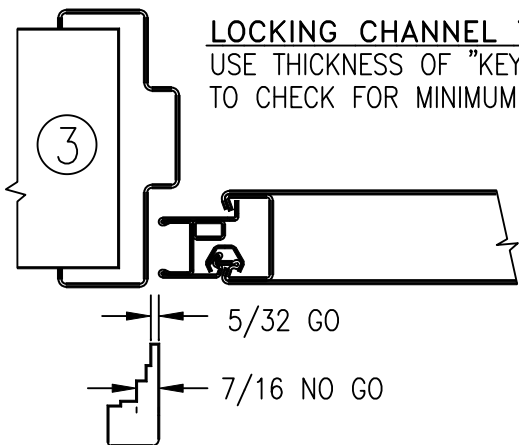

**LOCKING CHANNEL TO FRAME**  
USE THICKNESS OF "KEY" (3/32)  
TO CHECK FOR MINIMUM CLEARANCE

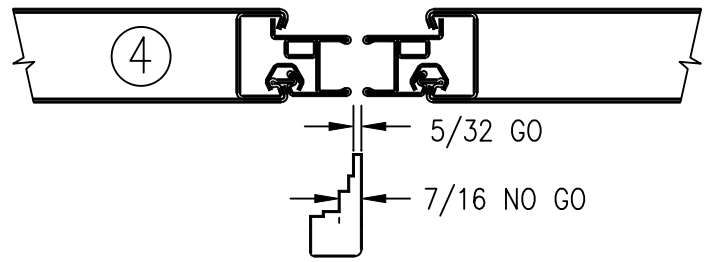

**LOCKING CHANNEL OF PAIRS**  
USE 5/32 PORTION OF "KEY" TO CHECK FOR  
MINIMUM CLEARANCE BETWEEN LOCKING CHANNELS.  
MEASURE PULL SIDE ONLY.

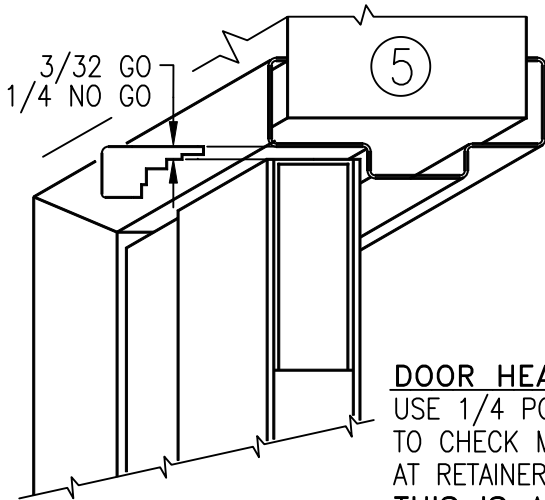

**DOOR HEAD TO FRAME**  
USE 1/4 PORTION OF "KEY"  
TO CHECK MAXIMUM CLEARANCE  
AT RETAINER.  
THIS IS A NO GO CHECK.

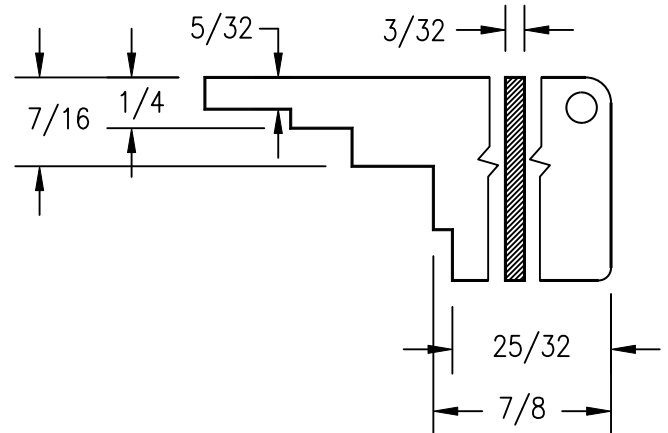

**TOTAL-DOOR INSTALLATION "KEY"**  
CHECKING OF INSTALLATION WITH THIS  
"KEY" WILL ASSURE SMOOTH, TROUBLE  
FREE OPERATION.